



imagination at work

2" Standard Port Flowgrid® Regulator and Shutoff Valve

Flanged CL 150, 300 NPT & SWE CL 300 Butt weld CL 300

The 2" Mooney Flowgrid Slam Shut is a combination of a regulator and a slam shut. In addition to pressure regulation, this pneumatically actuated device provides automatic downstream pressure protection. By separating the pneumatic controller and mechanical latching mechanism, shut off occurs only when designated set points are reached. The patent pending design prevents disruptive and costly "accidental shutoffs". Positive shutoff is achieved instantly through the snap acting mechanism, and reset can be completed with common tools.

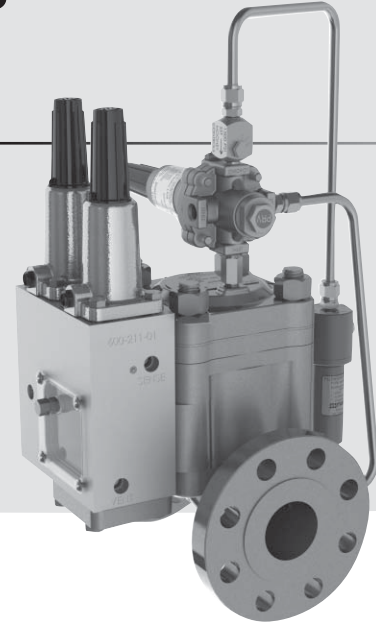

Flowgrid® Regulator with Integral Shutoff Valve, Series 60 Dual Function Controller, optional Series 20 Pilot, Type 24 Restrictor and Type 30 Filter.

Specifications

Size	2"
Body Style	Standard Port Slam Shut
End Connections	2" NPT CL 300, 2" SWE CL 300, 2" CL 150 RF Flange, 2" CL 300 RF Flange, 2" Butt weld CL 300
Temperature	Working -20°F to 150°F (-29°C to 65°C)
Minimum Differential	Refer to Graph on pg 2
Cracking Differential	Refer to Graph on pg 2
Maximum Inlet Pressure	740 psig (50 bar)
Outlet Pressure Range	Limited by SSV controller & Series 20 Pilot
Flow Direction	Uni-Directional
Taps	Four 1/4" - 18 NPT (one inlet, one center port*, one loading and one downstream)

*Center port - between flapper valve and regulator

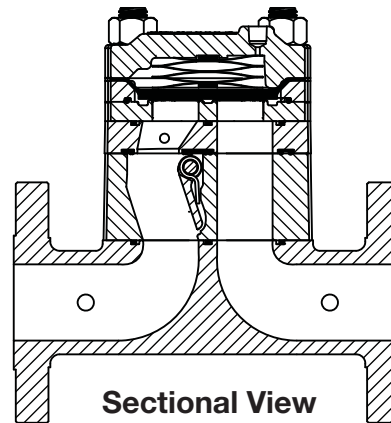

Sectional View

Materials of Construction

Body & Spring Case, Seal Retainer and Flapper Body	ASTM A 216 GR WCB Carbon Steel
Throttle Plate, Flapper and Shaft	17 - 4PH Stainless Steel or A515 Carbon Steel with ENC Coating
Diaphragm	Nitrile/Nylon*
O-Ring and Seals	Nitrile, Optional Viton®
Studs and Nuts	ASTM A 193 GR B-7 ASTM A 194 GR 2H or Equal
Springs	301 Stainless Steel ASTM A 313-03 17-17 SS
Bushings	Acetal

Stock Numbers

2" Standard Port Flowgrid Regulator & Shutoff Valve	Stock Number	Retrofit	Weight
NPT CL 300	SG-1	SR-1	61 lbs
SWE CL 300	SG-2	SR-2	60 lbs
150# Flange	SG-3	SR-3	71 lbs
300 # Flange	SG-4	SR-4	74 lbs
Butt weld CL 300	SG-76	SR-76	66 lbs

Dimensions

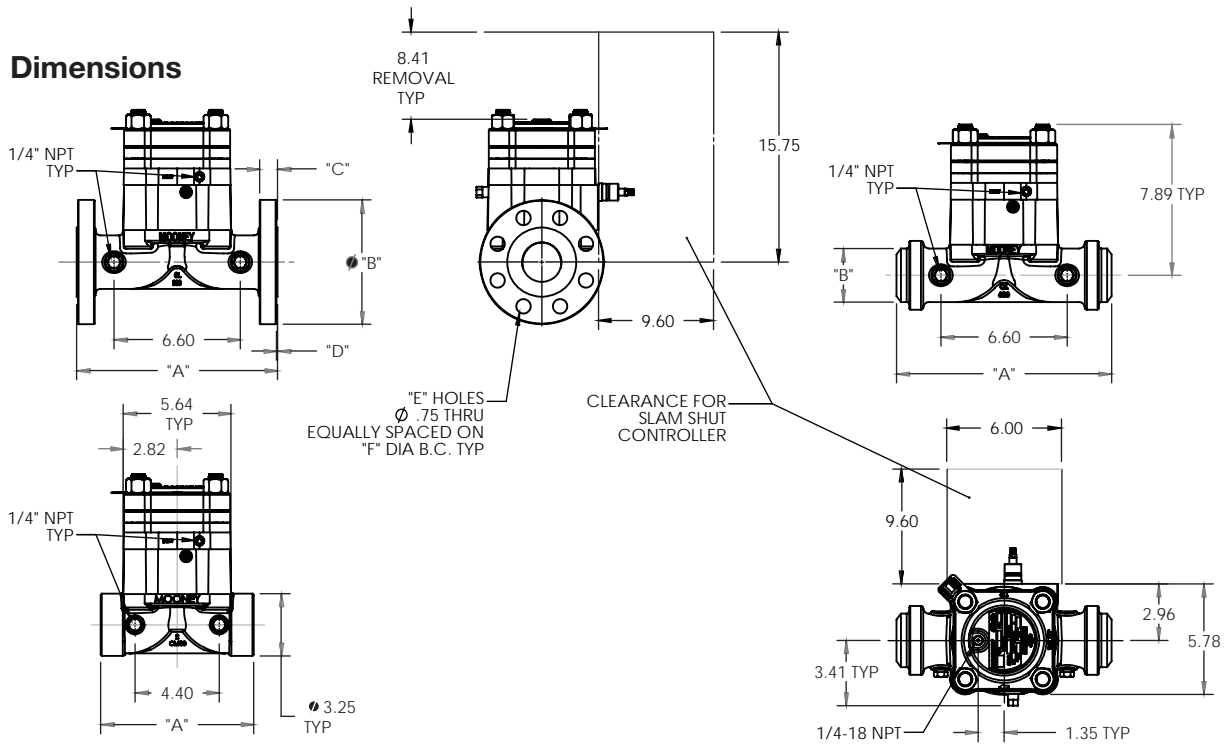

Flange Dimensions

Flange Class	A	B	C	D	E	F
Class 150	10.00	6.00	.75	.06	4	4.75
Class 300	10.50	6.50	.88	.06	8	5.00
Buttweld	11.25	2.80	-	-	-	-
NPT/SWE	8.00	-	-	-	-	-

Flow Coefficients and Constants*

2" Standard Port Percent	Flowgrid & Shutoff Valve			Swage Factor	
	C_v	C_1	C_g	1.5:1	2:1
100%	28	40	1130	0.98	0.97
75%	24	35	850	0.99	0.98
50%	21	52	680	1.00	0.98
35%	12	31	380	1.00	1.00

* Preliminary Data.

Minimum Pressure Differential vs. Capacity

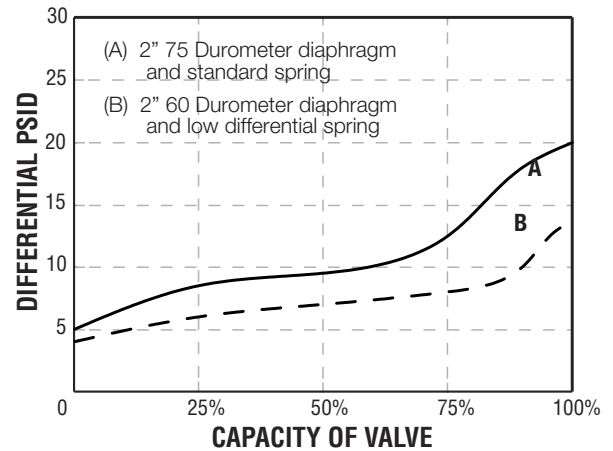

Diaphragm Selection

Compound	Temp. Range (Degrees F)	Maximum Differential	Characteristics	Recommended Applications
75 Duro	-20 to 150	1000 psid	Best All Around Material	60 psid to Max. Differential
60 Duro	-25 to 150	300 psid	Best Shutoff at Low Differential Pressure	Low Differential (100 psid or less) or Low Temperature
80 Duro High ACN	-5 to 175	1000 psid	Higher Abrasion and Swelling Resistance	High Differential (400 psid or higher) or Abrasive Conditions with Distillates
80 Duro Low ACN	-20 to 150	1000 psid	Higher Abrasion Resistance and Low Temperature Flexibility	High Differential (400 psid or higher) or Abrasive Conditions at Low Temperatures